



FIVE YEAR PUMP END WARRANTY ON ALL AUSSIE QUIK PRIME PUMPS

AUSSIE QUIK PRIME DIESEL DRIVE FIRE FIGHTING PUMPS

Model Numbers: **Aussie Fire Chief** **Aussie "Mr T"**
Aussie Fire Chief Plus **Aussie QP305**

The Aussie Fire Chief, Fire Chief Plus and "Mr T" super high pressure twin impeller fire pumps are available with diesel drive making them safer to use during fire duties as diesel is less flammable than petrol.

These pumps were designed with extraordinary performance, quality components and for ease of service, the Aussie Fire Chief is the choice of farmers and professional fire fighting authorities around the world.

Aussie Fire Chief (QP205SE)

Designed to out-perform and out-feature all other portable fire fighting pumps, the Aussie Fire Chief offers users significant quality features. These include a huge 7½" diameter, one piece impeller that weighs 2½ times more than impellers in other brands. The big belly body provides large water passages allowing more water to get through the pump and significantly aiding performance. The pump will produce flows of up to 400 litres per minute and heads as high as 60 metres. The pump is available with Yanmar, Kubota or Robin diesel engines and conforms with tough international environmental emission standards. The Fire Chief comes with anti vibration mounts and steel skids as standard equipment.

Aussie Fire Chief Plus (QP205SL)

A big single impeller Aussie Fire Chief pump but with either a Yanmar, Robin or Kubota diesel engine ranging from 7HP through to 10HP. Electric start option available on all models. Standard equipment includes full heavy duty roll frame with pump performance figures of up to 420 litres per minute flow, 65 metres head.

Aussie "Mr T" Twin Impeller Fire Pump (QP205SLT)

The Aussie "Mr T" is the final extension of development of the Aussie Fire Chief. It is a heavy duty twin impeller pump but with a difference!

The first stage is a large open impeller that gets lots of water into the pump. The second impeller, a large vaned, closed style, takes that water and hurls it through the pump creating combinations of high pressure and high flow that are unmatched, max head is 90 metres, max flow is 450 litres per minute.

The Aussie "Mr T" twin impeller range is available with a Yanmar diesel powered engine as standard with electric start. "Mr T" is available with 2" x 2" ports, 2" x 3-way ports (1½", 1", 1") or with 3" x 3".

Aussie QP305 3" High Pressure Pump

The 3" version of the Aussie Fire Chief, the QP305 is available in a wide range of options that provide flows of up to 530 litres per minute and heads as high as 60 metres.

Engine options include 7HP (recoil & electric start options) or 10HP electric start Yanmar diesel engines.



"Mr T" twin impeller fire pump with 2" discharge port fitted



Five Year Warranty:

Aussie Quik Prime pumps carry a unique pump end five year warranty. The products are guaranteed to be free of faulty workmanship or material for a period of five years after the date of sale to the end user.

Only top quality genuine brand engines by reputable Japanese manufacturers are used. A two year engine manufacturer's warranty applies, administered by the engine manufacturer or its duly appointed representative. All engines used by Australian Pump Industries are major international brands, serviced and supported not only in Australia and South Pacific but right throughout the world.



Due to our program of continuous product development the manufacturer reserves the right to alter specifications without notice.



FIVE YEAR PUMP END WARRANTY ON ALL AUSSIE QUIK PRIME PUMPS

AUSSIE QUIK PRIME DIESEL DRIVE FIRE FIGHTING PUMPS

Model Numbers: **Aussie Fire Chief** **Aussie "Mr T"**
Aussie Fire Chief Plus **Aussie QP305**

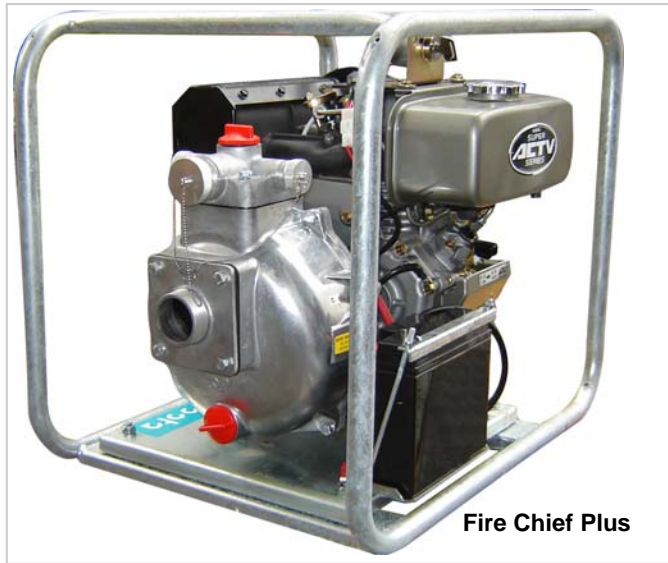

Fire Chief Plus

Applications:

- Fire fighting, mop up and general fire protection
- High pressure water transfer
- Spray irrigation
- Diesel fuel transfer
- High pressure spraying
- Sheep jetting
- Boom spraying
- Stock crate wash down
- Machinery wash down



Features

- Five year warranty
- Lightweight portable
- Fast self priming from 7.6 metres
- Replaceable suction port cover and discharge elbow
- Available with Yanmar, Kubota or Robin diesel engine (two year manufacturers warranty)
- Full frame with anti vibration mounts
- Single piece, heavy duty closed impeller
- Replaceable three way outlet
- Replaceable big 2 inch inlet
- Big belly body
- Three way outlet has top quality caps with metal chains
- Big drain port
- Big integrated priming port
- Optional Viton seal and o-ring kit
- Petrol drive engine versions
- Hydraulic drive option
- Electric start options

Benefits

- Great quality ... use with confidence
- Weighs from only 23kgs
- Ready to pump in minimum amount of time
- Easily replaced if thread damaged, easy to service check valve without dismantling pump
- Tried and proven with established service networks throughout the world, proven economy & longevity.
- Protects pump, facilitates transport on site
- Pumps more water at high pressure, saves fuel
- Enables choice of plumbing sizes from 1" to 1 1/2 "
- Lets more water into the pump, easy access to check valve
- Larger water passages mean more water efficiency, lower fuel costs
- Top quality, ensures outlet cap security
- Fast, easy pump draining
- Facilitates fast self priming
- Enables pump to be used in some herbicide or insecticide spraying applications
- Lighter option, makes it easier to carry
- Eliminates the need for a separate engine ... reduces costs

Model	Yanmar Option		Kubota Option		Robin Option		Max Head (m)	Max Flow (lpm)	Suction port	Discharge port	Self primes to (m)
	Model	HP	Model	HP	Model	HP					
Fire Chief (QP205SE)	L48	4.8	AC60 OC60E	6 6	DY23	4.8	60	400	2"	2x1", 1x1 1/2"	7.6
Fire Chief Plus (QP205SL)	L70 L100E	7 10	OC95E	9.5	-	-	65	420	2"	2x1", 1x1 1/2"	7.6
Mr T Twin impeller (QP205-TSLT)	L100E	10	-	-	-	-	90	450	2"	2x1", 1x1 1/2"	7.6
QP305	L70 L100E	7 10	-	-	-	-	60 60	470 530	3"	3"	7.6

Due to our program of continuous product development the manufacturer reserves the right to alter specifications without notice.



FIVE YEAR PUMP END WARRANTY ON ALL AUSSIE QUIK PRIME PUMPS

AUSSIE QUIK PRIME DIESEL DRIVE FIRE FIGHTING PUMPS

Model Numbers: Aussie Fire Chief Aussie Fire Chief Plus Aussie "Mr T" Aussie QP305

Construction:

Front case	Marine grade aluminium
Volute	Marine grade aluminium
Back plate	Marine grade aluminium
Mechanical seal	Carbon/ceramic
Outlet	Marine grade aluminium
Casing bolts	Zinc plated steel
Check valve	Nitrile rubber
Priming & drain plugs	Polycarbonate
Casing, priming & drain plug o-rings	Nitrile rubber
Finish	Brushed aluminium
Impeller	Marine grade aluminium, closed type

Dimensions:

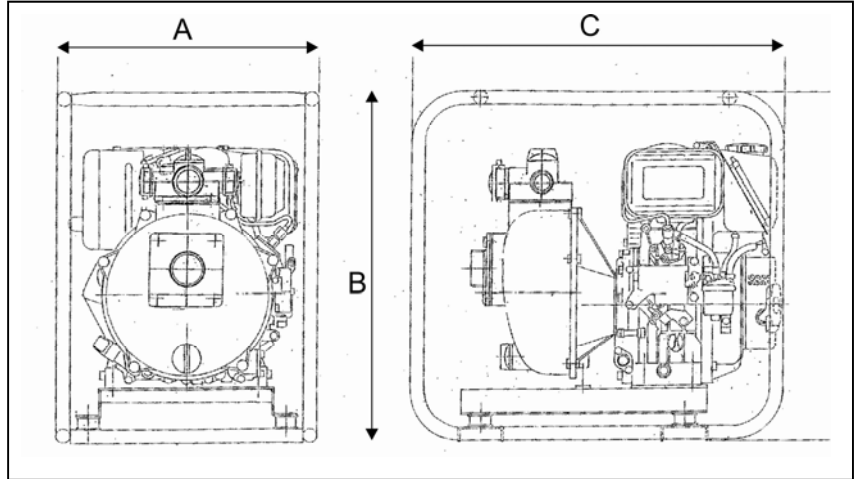

Model	Engine	A Width (mm)	B Height (mm)	C Length (mm)	Weight (kg)
Fire Chief QP205SE	L48	445	510	550	58
Fire Chief Plus QP205SE Aussie QP305	L70	560	680	760	75
Fire Chief Plus QP205SE Mr T Twin Impeller QP205SLT QP305	L100	560	680	760	90



QP305/L70E



QP205SE/DY23



QP205SE/AC60

Optional Accessories:

- Heavy duty suction hose
- Fire fighting hose kits including deluxe hose kit with two 20 metre delivery hoses and fire fighting nozzles
- Coupling Kit
- Strainer

Performance details and curves to be taken as a guide only

Performance Curve:

